

# Installation manual for charging rectifier type PCR3



## SAFETY INSTRUCTION



This manual must be read **before** installation, usage or work in the product.



**This product contains dangerous voltage that when touched can cause electrical shock, burn or death.**

The product must be installed by qualified personnel and according to the installation instructions. Service may only be performed by authorized service personnel. The protective cover of the connection compartment may only be removed by qualified personnel. Other protective covers may only be removed by authorized service personnel. **The power must always be disconnected** in a safe way before any service/maintenance work begins.



**WARNING!** Multiple power sources. Dangerous voltage is possible even with mains power shut off.

Manual 9-1578-D  
P/n 0001048

# CONTENTS

1	GENERAL .....	3
2	TECHNICAL DATA .....	4
2.1	ELECTRICAL DATA .....	4
2.1.1	Common electrical input data .....	4
2.1.2	Common electrical output data .....	4
2.1.3	Common electrical data for monitoring unit .....	4
3.1.4	Model depending electrical data .....	4
2.2	ENVIRONMENTAL DATA .....	5
2.3	MECHANICAL DATA .....	6
2.4	CONFORMITY WITH STANDARDS .....	7
3	INSTALLATION INSTRUCTIONS .....	8
3.1	SAFETY INSTRUCTIONS .....	8
3.2	MOUNTING .....	8
3.3	ELECTRICAL INSTALLATION .....	8
3.3.1	General .....	8
3.3.2	Connection of mains power .....	9
3.3.3	Connection of battery/load .....	9
3.3.4	Connection of measuring inputs .....	9
3.3.4.1	Connection of monitored battery voltage .....	9
3.3.4.2	Connection of measuring earth .....	10
3.3.4.3	Connection of temperature sensor .....	10
3.3.5	Connection of digital inputs .....	11
3.3.5.1	General .....	11
3.3.5.2	Connection of equalization charging blocking input .....	11
3.3.5.3	Connection of parallel operation control input .....	11
3.3.5.4	Connection of fuse monitoring input .....	11
3.3.5.5	Connection of rectifier blocking input .....	11
3.3.6	Connection of digital outputs .....	11
3.3.6.1	General .....	11
3.3.6.2	Connection of alarm output relays .....	12
3.3.6.3	Connection of battery compartment fan ventilator .....	12
3.3.7	Connection of serial data communication .....	12
3.3.7.1	General .....	12
3.3.7.2	Connection of KraftNet .....	12
3.3.7.3	Connection of I <sup>2</sup> C-bus .....	13
4	STARTING UP .....	14
4.1	SAFETY INSTRUCTIONS .....	14
4.2	SETTING ALIVE .....	14
4.3	START .....	14
4.4	CHECKING OF THE CHARGING VOLTAGE .....	14
4.5	CHECKING OF THE SETTINGS .....	14
4.6	CHECKING OF THE ALARM OUTPUTS .....	15
5	MAINTENANCE .....	16
5.1	SAFETY INSTRUCTION .....	16
5.2	ANNUAL INSPECTION .....	16
5.2.1	Checking of charging voltage .....	16

5.2.2	Checking of measuring instrument	16
5.2.3	Checking of alarm circuits	16
5.2.4	Checking of fans and filters	16
5.3	5-YEAR INSPECTION	16
6	FAULT TRACING	17
6.1	SAFETY INSTRUCTION	17
6.2	FAULT TRACING BY AN ALARM	17
6.3	OTHER FAULT TRACING	17
7	OTHER DOCUMENTS	19
	CIRCUIT DIAGRAM PCR3	20
	CIRCUIT DIAGRAM PCR3L	21
	ADDITIONS AND CHANGES	22

*We retain the rights to make changes to these specifications without further notice.*

## 1 GENERAL

Charging rectifier type PCR is a primary switched mode charging rectifier family with integrated monitoring unit.

This description only treats charging rectifiers in 3-phase variant, i.e. charging rectifiers with type designations PCR3 and PCR3L. The description mainly applies to designers and personnel that are responsible for installation, service and maintenance.

For information regarding usage of the charging rectifier, see the *Users manual*.

For systems with charging rectifiers in parallel operation and double DC-systems, additional information can be found in the *Supplementary installation manual*.

The term "charging rectifier" will henceforth be substituted by the term "rectifier".

By safety reasons, concerned personnel are divided into different classes with the following demands on specific qualifications:

**Authorized service personnel:**

- Has electrical education and adequate experience to avoid the dangers that electricity can cause.
- Has certificated qualification according to competent authorities for the work in question.
- Has knowledge of languages that implies that the content in this description can not be misunderstood.
- Has went through a product specific education programme for authorized service personnel that is approved by Kraftelektronik AB.

**Qualified personnel:**

- Has electrical education and adequate experience to avoid the dangers that electricity can cause.
- Has certificated qualification according to competent authorities for the work in question.
- Has knowledge of languages that implies that the content in this description can not be misunderstood.

## 2 TECHNICAL DATA

### 2.1 ELECTRICAL DATA

#### 2.1.1 Common electrical Input data

Rated voltage . . . . .	380/400/415 V <sub>AC</sub> 3-phase
Input voltage, range . . . . .	342 - 457 V <sub>AC</sub>
Rated voltage . . . . .	440 - 480 V <sub>AC</sub> 3-phase
Input voltage, range . . . . .	396 - 528 V <sub>AC</sub>
Frequency . . . . .	45 - 65 Hz
Power factor . . . . .	0.97 (fundamental at nominal load)
Terminal block, PCR3 . . . . .	0 - 10 mm <sup>2</sup>
Terminal block, PCR3L . . . . .	0.2 - 2.5 mm <sup>2</sup>

#### 2.1.2 Common electrical output data

Output voltage . . . . .	See "Model depending electrical data"
Voltage regulation (static) . . . . .	<±0.5 % of nominal output voltage (U <sub>NOM</sub> )
Voltage regulation (dynamic <sup>①</sup> ) . . . . .	<±1 % within 3 seconds
Setting range, float charging . . . . .	0 - maximum output voltage (U <sub>MAX</sub> )
Setting range, equalizing charging . . . . .	0 - maximum output voltage (U <sub>MAX</sub> )
Current regulation . . . . .	<±1 % of rated current (I <sub>RATED</sub> )
Setting range, current limit . . . . .	0 - 100 % of rated current (I <sub>RATED</sub> )
Ripple voltage, PCR3 . . . . .	<0.2 % <sub>RMS</sub>
Ripple voltage, PCR3L . . . . .	<0.7 % <sub>RMS</sub>
Ripple current . . . . .	<1 % of rated current (I <sub>RATED</sub> )
Efficiency, typical . . . . .	93 %
Terminal block, PCR3 . . . . .	10 - 70 mm <sup>2</sup>
Terminal block, PCR3L . . . . .	0.75 - 50 mm <sup>2</sup>

① during change of load 0-100 % and 100-10 % respectively.

#### 2.1.3 Common electrical data for monitoring unit

Voltage measuring, inaccuracy . . . . .	<±0.2 % of nominal output voltage (U <sub>NOM</sub> )
Voltage measuring, range . . . . .	See "Model depending electrical data"
Current measuring, inaccuracy . . . . .	<±1 % of rated current (I <sub>RATED</sub> )
Current measuring, range . . . . .	0 - 100.9 % of rated current (I <sub>RATED</sub> )
Battery temperature measuring, inaccuracy . . . . .	<±1.5 °C
Battery temperature measuring, range . . . . .	0 - 50 °C
Earth fault resistance measuring, inaccuracy . . . . .	<±15 %, 50 kΩ - 1 MΩ
Earth fault resistance measuring, range . . . . .	0 - 5 MΩ
Earth fault terminal, internal resistance R <sub>IN</sub> . . . . .	>200 kΩ (24 - 220 V), >900 kΩ (440 - 500 V)
Pluggable terminal block for monitoring . . . . .	0-2.5 mm <sup>2</sup>
Alarm relay, contact data, maximum . . . . .	AC: 250 V 8 A DC:125 V 0.15 A (30 V, 5 A) at L/R=7 ms

**3.1.4 Model depending electrical data**

Model of PCR3	Output data					Connection data			Rectifier unit	Monitoring unit
	U <sub>NOM</sub>	U <sub>MAX</sub>	I <sub>RATED</sub>	Recommended number of cells		Mains power	Mains current	Mains fuse, maximum	Maximum loss of power	Voltage measuring range
	(V)	(V)	(A)	Lead	Alkal.	(VA)	(A <sub>RMS</sub> )	(A <sub>SLOW</sub> )	(W)	(V)
PCR3 24/100	24	32	100	11-13	17-21	6300	9	16	620	35.84
PCR3 48/60	48	60	60	22-26	35-40	7620	11	16	390	71.68
PCR3 48/100	48	60	100	22-26	35-40	11570	17	20	730	71.68
PCR3 110/30	110	150	30	52-54	78-85	7650	11	16	280	163.8
PCR3 110/50	110	150	50	52-54	78-85	11780	17	20	580	163.8
PCR3 110/100	110	150	100	52-54	78-85	21500	31	35	920	163.8
PCR3 125/30	125	160	30	55-60	86-92	8310	12	16	310	163.8
PCR3 125/75	125	160	75	55-60	86-92	18300	27	35	750	163.8
PCR3 220/25	220	280	25	102-112	156-184	12150	18	25	470	327.7
PCR3 220/50	220	280	50	102-112	156-184	22200	32	35	770	327.7
PCR3L 440/7	440	500	7	204-216	270-306	6300	10	16	270	614.4
PCR3 440/10	440	500	10	204-216	270-306	9430	14	16	160	614.4
PCR3 440/15	440	500	15	204-216	270-306	13800	20	25	350	614.4
PCR3 440/25	440	500	25	204-216	270-306	21400	31	35	700	614.4
PCR3 500/10	500	550	10	240-252	320-356	10950	16	20	190	614.4
PCR3 500/20	500	550	20	240-252	320-356	20450	30	35	590	614.4

**2.2 ENVIRONMENTAL DATA**

Class of enclosure . . . . . IP20 according to SS-EN 60529  
Cooling . . . . . By fan ventilator  
Ambient temperature (specified data is valid) . . . . . 0 to +40 °C  
Ambient temperature (specified data is not valid) . . . . . +40 to +50 °C at reduced power ①  
Storage temperature . . . . . -40 to +70 °C  
Humidity . . . . . <90 %RH  
Altitude above sea level . . . . . <1000 m  
Noise level . . . . . <55 dBA

① Above +40 °C, the rated output current is decreased 3.5 % for every additional 1 °C. This must be manually adjusted, see *Users Manual*, section *Operation, Settings, Adjust current limit level*.

**2.3 MECHANICAL DATA**

Weight ..... 47 kg, valid for PCR3 model 24/100, 48/60, 110/30, 125/30, 220/15, 440/10  
 52 kg, valid for PCR3 model 48/100, 110/50, 110/100, 125/75, 220/25,  
 220/50, 440/15, 440/25, 500/10, 500/20  
 17 kg, valid for PCR3L  
 Arrangement ..... Wall mounting  
 Dimensions ..... See dimensional drawing below  
 Colour ..... RAL 7035

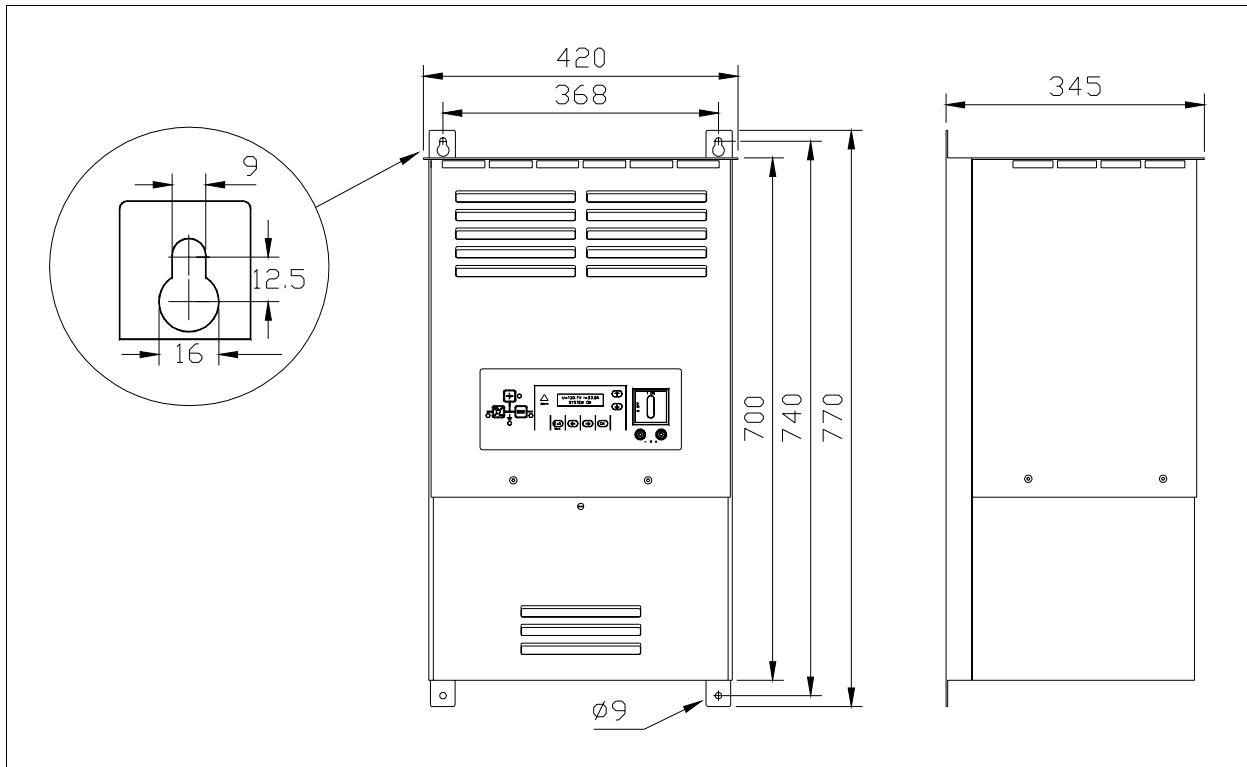

*Dimensional drawing, PCR3*

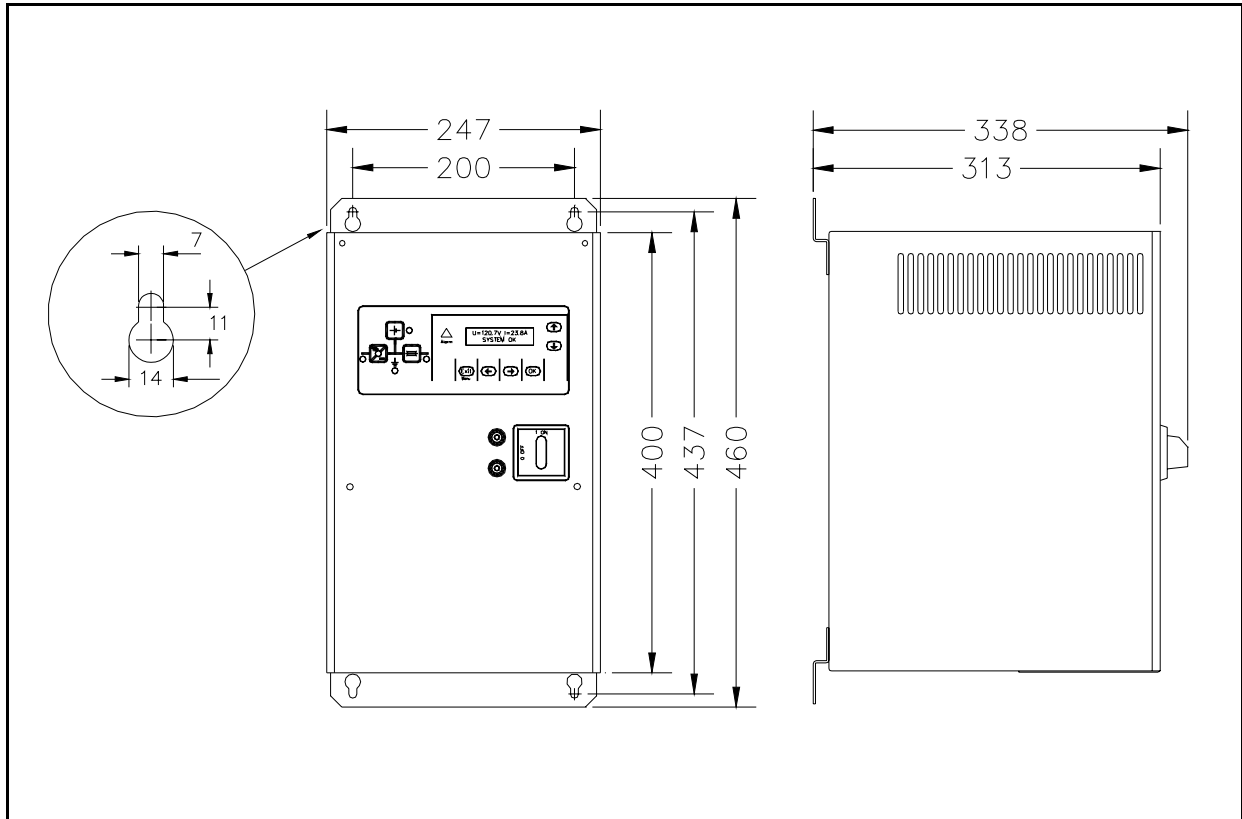

*Dimensional drawing, PCR3L*

## 2.4 CONFORMITY WITH STANDARDS

- SS-EN 50081-2 . . . . . EMC. Generic emission standard, light industry.
- SS-EN 50082-2 . . . . . EMC. Generic immunity standard, industrial environment.
- SS-EN 50178 . . . . . LVD. Electronic equipment for use in power installations.
- SS-EN 60529 . . . . . Class of enclosure, IP20.

### 3 INSTALLATION INSTRUCTIONS

#### 3.1 SAFETY INSTRUCTIONS



**WARNING!** This product contains dangerous voltage that when touched can cause electrical shock, burn or death. Protective earth must **always** be properly connected. No alive parts is permitted during installation. The product must be installed by qualified personnel (see chapter 1, *General*).



**WARNING!** Check both before and after setting-up that the product does not have any mechanical damages. Cables for input and output power must be correctly dimensioned to avoid fire hazard. Supply main transformer should be star-connected with protective earth connected to its centre.

#### 3.2 MOUNTING

The rectifier is intended for wall mounting indoors in a room that is dry, clean and free from conductive dust. Mounting should be done in such way that free air for all vent openings are provided for.

First, fasten the two upper mounting bolts on the wall. Then, fit in the "keyhole" tappings on the rectifier so the rectifier is hanging on the bolts. Finally, fasten the two lower mounting holes.



**CAUTION!** Due to a fall, the device can cause physical injury and damage on property. Always use safe lifting equipment. Carefully ensure that mounting bolts and their attachment into the wall, with safe margin and in a safe way, are able to carry the weight of the rectifier.

#### 3.3 ELECTRICAL INSTALLATION

##### 3.3.1 General

Only permanent mains feeding connection is permitted. Protective earth must be connected before any other installation. All installations are made in the so called "connection compartment" (see the component location drawing below).

PCR3: Remove the lower part of the enclosure that covers the connection compartment by undoing the screw on the upper part of the cover.

PCR3L: Remove the four screws on the front and undo the two on the underside. Then lift off the cover by pulling outwards.



**WARNING!** Hold the cover carefully when undoing the screw, or else the cover may fall down and cause damage or injury.

X16														X11												X8				X7	
ALARM RELAY A			ALARM RELAY B			ALARM RELAY C			ALARM RELAY D			FAN OUT-PUT		KRAFT-NET		EQ. DIS-ABLE		PARAL-LEL		FUSE FAULT		EXT. BLOCK-ING		EXT. TEMP. SENSOR		MEASUREMENTS				12C BUS	
C	NC	NO	C	NC	NO	C	NC	NO	C	NC	NO	C	NO	C	NC											⊥	U-BATTERY				
1	2	3	4	5	6	7	8	9	10	11	12	13	14	1	2	3	4	5	6	7	8	9	10	11	12	1	2	3	4		

*Terminals for measurings and signals*

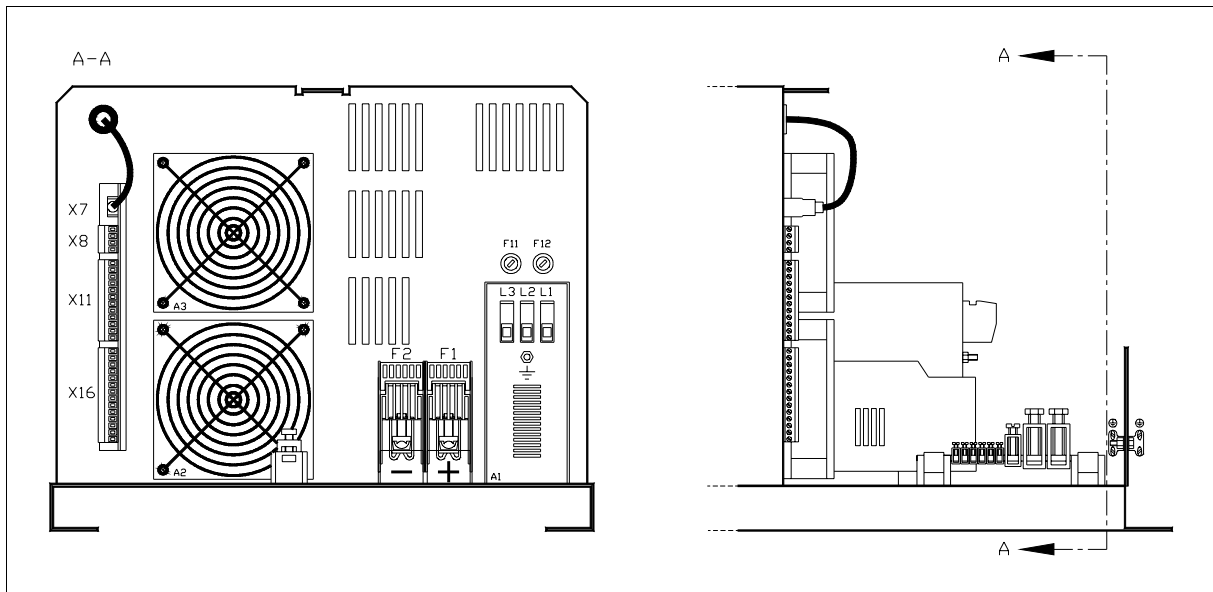

Component locations, connection compartment PCR3

### 3.3.2 Connection of mains power

The required primary fuse rating is stated in the table found in section *Technical data*, or in appendix *Additions and changes* if the rectifier has non-standard primary data.

Connect 3-phase mains voltage to the three terminal blocks marked L1, L2 and L3. The phase sequence is of no importance.

### 3.3.3 Connection of battery/load

Verify that the rated voltage specified on the rectifier marking sign corresponds to the nominal voltage of the battery. Choose cables that can handle the rated current of the rectifier.

PCR3: Connect the DC system to the output fuse terminals marked + and - respectively. The rectifier output is supplied with two-pole fusing.

PCR3L: Connect the DC system to output terminals marked L+ and L- respectively. The rectifier output is not supplied with internal fuses. External fuses should be arranged.

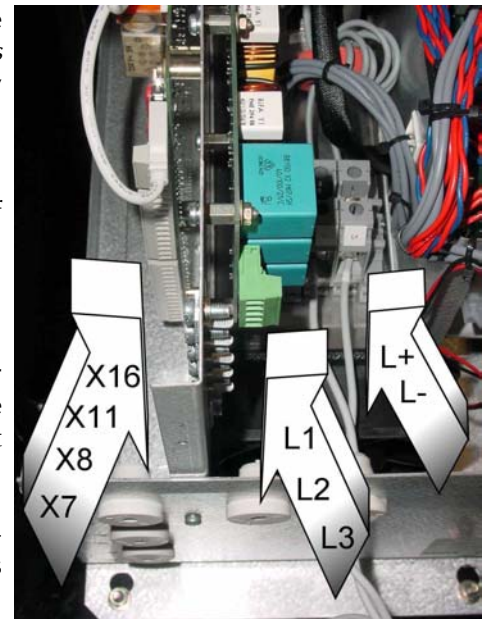

Component locations, PCR3L

### 3.3.4 Connection of measuring inputs

#### 3.3.4.1 Connection of monitored battery voltage

All the voltages that are monitored should be measured as close to the battery and distribution unit as possible in order to avoid measuring errors due to voltage drop in cables.

*U<sub>battery-</sub>* is the minus pole common to all the voltage measurements. Connect from the minus pole of the battery to terminal X8:2.

*U<sub>battery+</sub>* measures the total voltage of the battery. Connect from the plus pole of the battery to terminal X8:4.

*U<sub>battery</sub><sup>1/2</sup>* measures the midpoint voltage of the battery. Connect from the mid point of the battery to terminal X8:3.

By measuring the voltage level of the mid point of the battery and thereby compare the two halves, you can in a simple but effective way catch a number of important fault conditions as for example unequal charging distribution, short-circuit in battery cells, etc.

If the midpoint voltage should be used, the midpoint voltage measuring must be activated and set with the proper parameters, see *Users Manual*, section *Operation, Selection of functions, Midvoltage*.

The parameter that is set states the percentage of the total battery voltage that is expected in the mid point. It will not always be exactly 50% because it is not always possible to make a connection in the theoretical mid point. Therefore, always check that the actual measuring point corresponds to the setting.

#### 3.3.4.2 Connection of measuring earth

Earth fault measuring are done by continuously measuring the voltage in a constructed midpoint to which the monitored earth point is connected.

If earth fault measuring is used, connect terminal X8:1 to the earth distribution bar that is found in the connection compartment.

Note that the measuring point must not be located outside the connection compartment by EMC reasons. In those cases you need a disconnectable measuring earth, e.g. in double DC systems, you can use the internal facility for disconnection of the measuring earth. The disconnection control is handled via the digital input for parallel operation. Additional information can be found in the *Supplementary installation manual*.

Earth fault measuring can be disabled, see *Users Manual*, section *Operation, Selection of functions, Earth fault measuring*. A galvanic separation of the measuring input terminal will then be done internally without the need of any external disconnection.

#### 3.3.4.3 Connection of temperature sensor

Measuring of the battery temperature is needed if you intend to use temperature regulated float charging voltage. At the same time you get a monitoring of extreme temperatures with matching alarms.

The external temperature sensor is a standard Pt-1000 resistive sensor built into a hermetic sealed enclosure, commercially named "outdoor sensor". Since the sensor is of the type Pt-1000, a two pole measuring will do, in contrast to the more commonly used Pt-100 that usually needs a four-pole measuring to prevent the measuring wire resistance to have an effect on the measuring result.

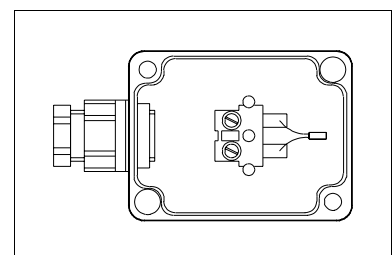

*Temperature sensor (without covering)*

Place the sensor on a spot that will best represent the battery temperature, normally the most central located point on the top of the battery.

Connect the temperature sensor to terminal X11:11-12.

The temperature sensor is an option and is therefore installed only whenever applicable. If a temperature sensor should be used, the temperature measuring function must be enabled, see *Users Manual*, section *Operation, Selection of functions, Temperature measuring*.

### **3.3.5 Connection of digital inputs**

#### **3.3.5.1 General**

The digital inputs are power supplied from the internal auxiliary power of the rectifier (approximately 12VDC) that is galvanically tied to the output minus-pole. Therefore, they may only be connected to zero-potential contacts.

Closed input means normal state. Open input is activated state. It means that the two terminals of each input that is not used must be interconnected!

#### **3.3.5.2 Connection of equalization charging blocking input**

In open state, the equalization charging is prohibited. Is mainly used to, via a vent flow monitor, prevent equalization charging in case of a malfunctioning battery compartment fan ventilator.

Is connected to terminal X11:3-4.

#### **3.3.5.3 Connection of parallel operation control input**

Open input means that the DC system in which the rectifier is part of, operates in connection with another DC system. It means, among other things, that the earth fault measuring automatically is measured in only one rectifier in the complete double DC system. For additional information, see the *Supplementary installation manual*.

Is connected to terminal X11:5-6.

#### **3.3.5.4 Connection of fuse monitoring input**

Monitors an optional number of fuses through auxiliary fuse contacts connected in series. Open loop means tripped fuse.

Is connected to terminal X11:7-8.

#### **3.3.5.5 Connection of rectifier blocking input**

An open input immediately results in a shutting off of the rectifier. Is functionally placed side by side with the mains switch in off position.

Is connected to terminal X11:9-10.

### **3.3.6 Connection of digital outputs**

#### **3.3.6.1 General**

The digital outputs consists of zero-voltage relay contacts. Electrical ratings for the contacts are found-in section *Electrical data* earlier in this chapter.

The terminals for the outputs are marked C, NC and NO respectively. The implication of this is:

- C - Point for Common connection.
- NC - Connection point for Normally Closed contact.
- NO - Connection point for Normally Open contact.



### 3.3.7.3 Connection of I<sup>2</sup>C-bus

The I<sup>2</sup>C bus is always connected using a cable assembly of so called USB-type (commonly used between computers and their peripheral units). In a standard PCR3 rectifier, the cable assembly is already connected with one end visible in the terminal X7 while the other end disappears into the rectifier where it is connected to the display unit. In those cases where the display unit should be mounted in some other way or other peripheral units should be connected, then see the separate installation instructions that should be supplied for this matter.

## 4 STARTING UP

---

### 4.1 SAFETY INSTRUCTIONS



**WARNING!** This product contains dangerous voltage that when touched can cause electrical shock, burn or death. All protective coverings and plates must be mounted during operation.



**NOTE!** Due to risk of condensation, the product should have reached room temperature before commissioning.

---

### 4.2 SETTING ALIVE

First, connect battery power, for instance by using a fuse to close the battery circuit. The monitoring unit will now start. Note that a starting current surge occurs when the filter capacitors in the rectifier are charged. It may cause sparking at the engaging point.

The set the voltage measuring inputs alive.

At last, switch on the mains power.

---

### 4.3 START

Turn the panel mains switch in position 1 (On).

Battery charging now commences. If the battery was deeply discharged, charging will commence at the rated current, and this will continue until the float charging level is reached. Some battery types needs an initial equalizing charging. Always follow the instructions stated by the battery manufacturer.

---

### 4.4 CHECKING OF THE CHARGING VOLTAGE

Check that the rectifier voltage settings corresponds to the specifications stated by the battery manufacturer, see *Users manual*, section *Operation, Settings*.

When the battery reached such a charging level so that the alarm "High current" no longer is active, you should check that the actual output voltage really corresponds to the preset float charging voltage. See section *Maintenance, Annual inspection, Checking of charging voltage*

---

### 4.5 CHECKING OF THE SETTINGS

Check that displayed measures corresponds to real values. Check alarm settings and other parameters so they corresponds to intended function, see *Users manual*, section *Operation*.

For maximum safety, see that the OVP function (OverVoltage Protection) is activated (see *Users manual*, section *Operation, Advanced, Selection of functions, Overvoltage protection*). The protection is normally activated at the time of delivery.

---

---

#### **4.6 CHECKING OF THE ALARM OUTPUTS**

The alarm relays A-D can be manually manoeuvred for checking of the external circuits that are connected to the alarm output relays, see *Users manual*, section *Operation, Test*.

## 5 MAINTENANCE

---

### 5.1 SAFETY INSTRUCTION



**WARNING!** This product contains dangerous voltage that when touched can cause electrical shock, burn or death. Maintenance work that involves work with removed connection compartment protective covering may only be done by qualified personnel.

Ensure that the apparatus has been in a dead condition for at least 5 minutes, giving the internal circuits time to discharge before any protective coverings are removed.

---

### 5.2 ANNUAL INSPECTION

#### 5.2.1 Checking of charging voltage

Connect an external voltmeter to the panel voltmeter terminals and check that the output voltage corresponds to the preset value.

Note that if the float charging voltage is temperature regulated, the rectifier must be forced into a state where the temperature regulation stops in order to make the checking possible. In order to achieve this state and by trimming eliminating a possible divergence, see *Users manual*, section *Operation, Trimming of rectifier*.

#### 5.2.2 Checking of measuring Instrument

Check that the internal measuring instrument (display) shows a correct value. Follow the instructions stated in the *Users manual*, section *Operation, Calibration of measuring instrument*.

#### 5.2.3 Checking of alarm circuits

Check the circuits that are parts of the alarm system. Follow the instructions stated in the *Users manual*, section *Operation, Test*.

#### 5.2.4 Checking of fans and filters

The connection compartment there is either one or two cooling fans. Check that the fans are functioning properly. Listen for jarring sounds that may indicate worn out bearings and in that case, replace the fans in preventing purpose. If the fans are supplied with filters, the filters should be replaced.



**NOTE!** After fan replacement, check that the direction of the air flow is still turned upwards inside the apparatus.

If you suspect that there is any substantial amount of dust in the rectifier, call for authorized service personnel. Do under no circumstances own encroachments into the apparatus.

---

### 5.3 5-YEAR INSPECTION

Beyond the annual inspection, the cooling fans should be replaced in preventing purpose.

---

## 6 FAULT TRACING

---

### 6.1 SAFETY INSTRUCTION



**WARNING!** This product contains dangerous voltage that when touched can cause electrical shock, burn or death.

Service/maintenance work that involves work with removed connection compartment protective covering may only be done by qualified personnel. Other protective coverings may only be removed by authorized service personnel.

Ensure that the apparatus has been in a dead condition for at least 5 minutes, giving the internal circuits time to discharge before any protective coverings are removed.



**WARNING!** Overvoltage can cause explosion of electrolytic capacitors and varistors. If work has to be done with power applied, a splinter screen therefore must be used (safety goggles or shielding).

---

### 6.2 FAULT TRACING BY AN ALARM

When there is an alarm message, the fault tracing should in first case be based on the information given in the *Users manual*, section *Operation*, *Alarm messages*, *Alarm descriptions*. Only after that, or if there are no relevant alarms, you proceed to the instructions in section *Other fault tracing*.

---

### 6.3 OTHER FAULT TRACING

#### **The primary fuse is tripping when the rectifier is turned on**

- Cause 1: Incorrect type of mains fuse. Check that mains fuse follows the specifications in section *Technical data*. Note that delayed-action fuses must be used.
- Cause 2: Pause between two or more switch-on operations are too short. The internal current limiting resistor has not been given time to cool down. Replace the fuse and make at least 1 minute pause between operations.
- Cause 3: Internal rectifier fault. Call for authorized service personnel.

#### **No rectifier output**

- Cause 1: The output fuses has tripped. Check that the output fuse rating is sufficient compared to the rated output current of the rectifier.
- Cause 2: The input for external blocking is in open state.
- Cause 3: Internal rectifier fault. Call for authorized service personnel.

#### **The rectifier output voltage is too low**

- Cause 1: High temperature in the battery or battery compartment. Applicable only if the output voltage is temperature regulated. In that case, the rectifier is O.K. Instead, seek the cause of the high temperature. The temperature sensor may also be faulty. Check if the display reports correct battery temperature.
- Cause 2: Incorrect setting of float charging voltage level. Change the setting.
- Cause 3: Incorrect trimming of output voltage. Make a new trimming of the output voltage.
- Cause 4: Internal rectifier fault. Call for authorized service personnel.

#### **The rectifier output voltage is too high**

- Cause 1: Low temperature in the battery or battery compartment. Applicable only if the output voltage is temperature regulated. In that case, the rectifier is O.K.

- Instead, seek the cause of the low temperature. The temperature sensor may also be faulty. Check if the display reports correct battery temperature.
- Cause 2: Incorrect setting of float charging voltage level. Change the setting.
- Cause 3: Incorrect trimming of output voltage. Make a new trimming of the output voltage.
- Cause 4: Internal rectifier fault. Call for authorized service personnel.

**The rectifier output current is too high**

- Cause 1: Incorrect setting of current limit. Change the setting.
- Cause 2: Internal rectifier fault. Call for authorized service personnel.

**Cooling fan is not rotating, eventually together with the alarm "High temp, rect"**

- Cause: Faulty fan. Replace the fan.

**The rectifier sound odd**

- Cause: In an idling running state there might be a twittering sound. This is no fault but is completely normal. The sound will disappear as soon as even a minor load is impressed.

**The display is turned off but the rest of the rectifier is functioning**

- Cause 1: The I<sup>2</sup>C cable has come loose from the connector X7. Restore the connection. The display backlight now should be turned on but then it may take as long as one hour before the display shows relevant information again. It might happen that the alarm "Internal fault xx01" then is shown. Acknowledge the alarm and it should not come back.
- Cause 2: Internal rectifier fault. Call for authorized service personnel.

**The pushbuttons doesn't work and/or the display shows rubbish**

- Cause 1: Indicates that the internal microcomputer has locked up. The control electronics has to be restarted by first making it dead. The dead state is achieved by first turning off the rectifier using the mains switch and then disconnect the rectifier from the battery. This is most easily done by removing the rectifier output plus-pole fuse. Let it remain open for a while until the display has completely turned off. Then restart by restoring the fuse and then turn on the rectifier mains switch again.
- Cause 2: Internal rectifier fault. Call for authorized service personnel.

## **7 OTHER DOCUMENTS**

As appendixes follows on following pages in turn:

- Circuit diagram PCR3
- Circuit diagram PCR3L
- Additions and changes

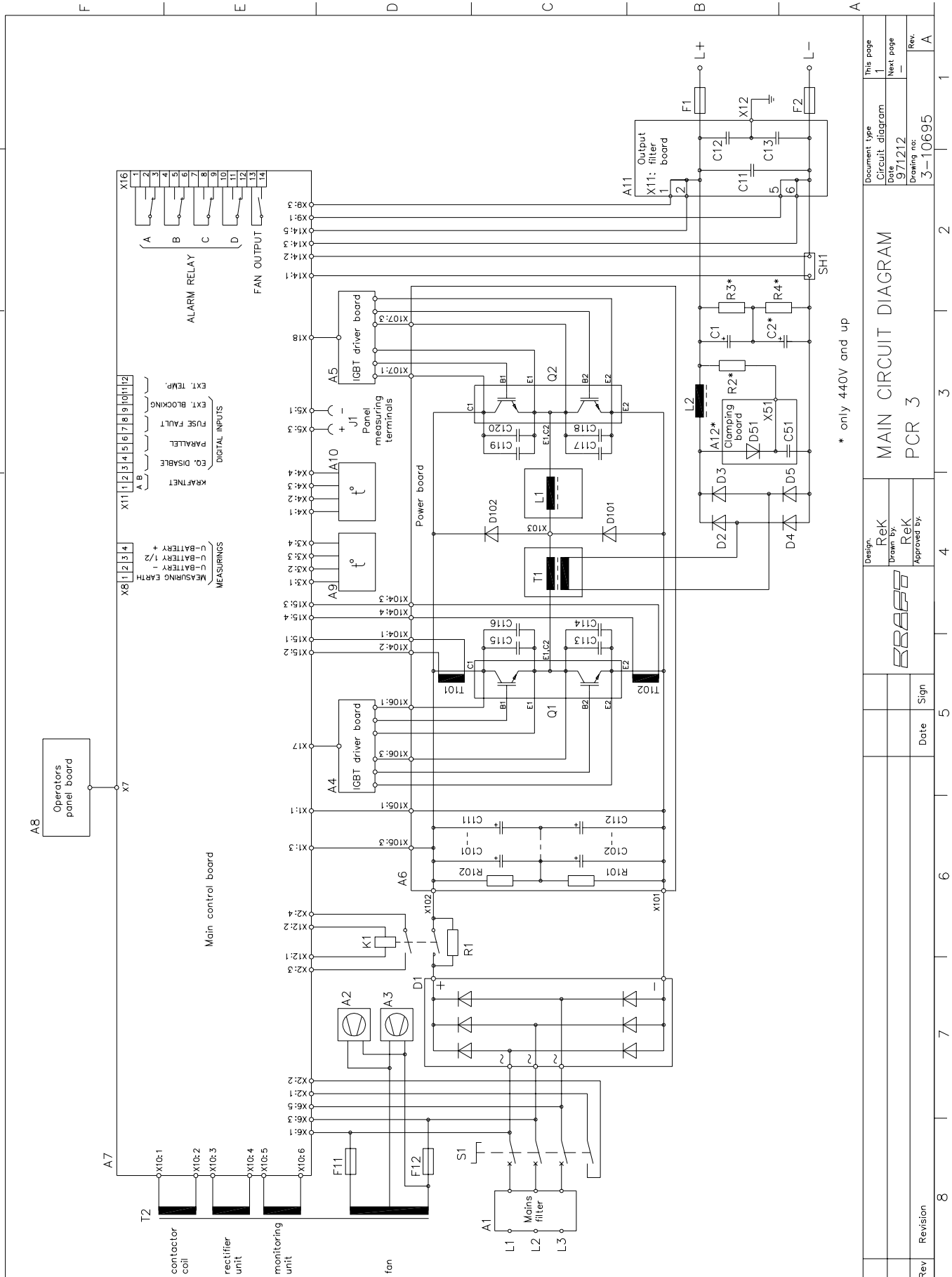

Rev	Revision	8
Date	Sign	5
Rek	Rek	4
Design	Rek	4
<b>BBB</b>		
MAIN CIRCUIT DIAGRAM		
PCR 3		
Document Type	This page	1
Circuit diagram	Next page	1
Date	9/12/12	-
Drawing no:	3-10695	-
Rev.	A	1

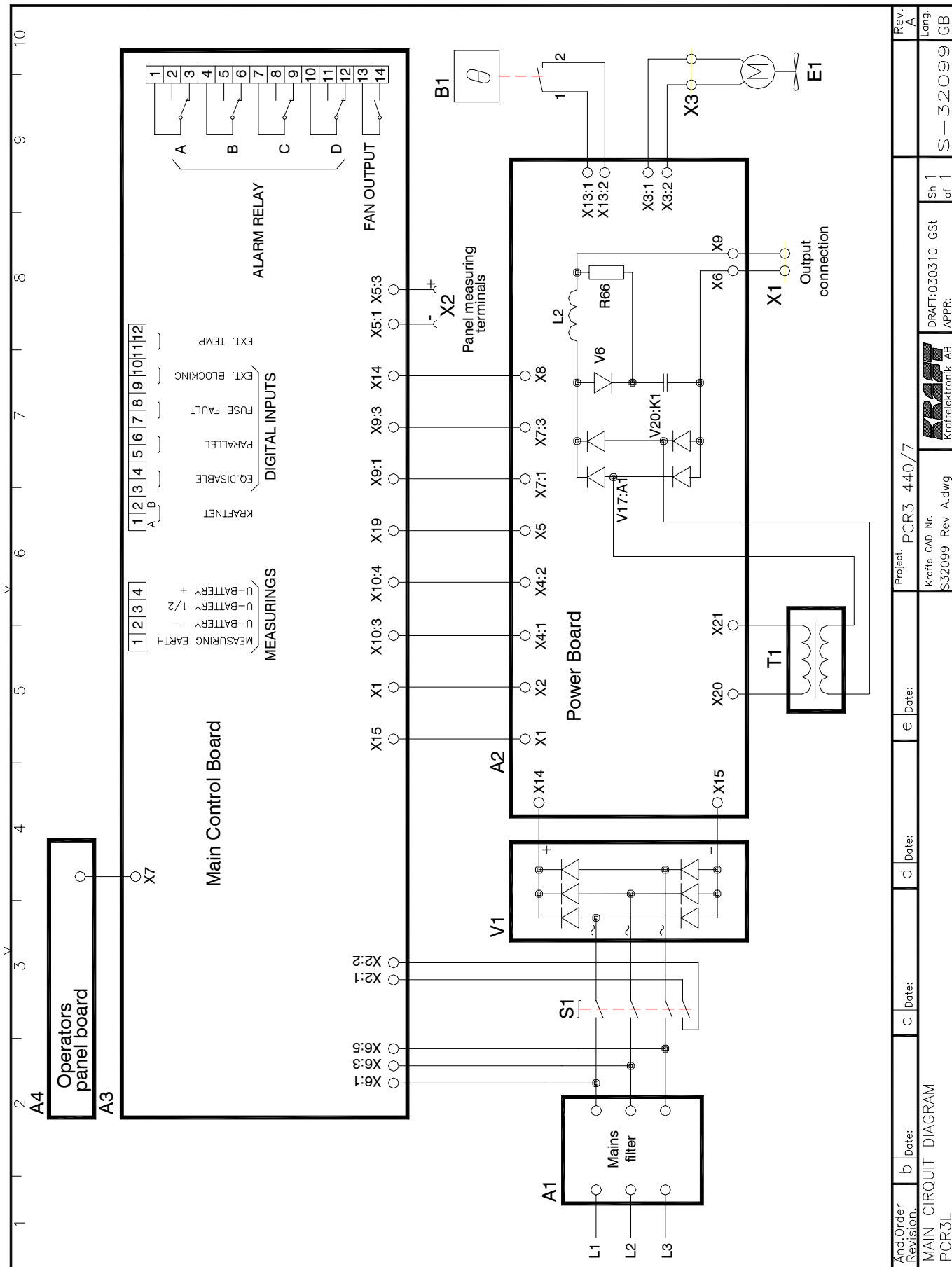

Änd./Order Revision:	b	Date:	c	Date:	d	Date:	e	Date:	Project:	PCR3 440/7	Rev.:	A
MAIN CIRCUIT DIAGRAM	Krafts CAD Nr. S32099			DRAFT:030310			GST			Sh 1 of 1	Lang:	GB
PCR3L	Rev. A.dwg			APPR:			Kraftelektronik AB			S-32099		

**ADDITIONS AND CHANGES**

